

SPECIFICATIONS

Model Name	WM-AI Type		AS1 JR	AS2 JR	AT1 JR	AT2 JR	
Scale Unit	Weighing Capacity *1	0 - 3kg × 0.001kg / 3 - 6kg × 0.002kg		○			
		0 - 6kg × 0.002kg / 6 - 15kg × 0.005kg		○			
		0 - 15lb × 0.005lb / 15 - 30lb × 0.01lb			○		
	Weighing Accuracy	1/3000 (Dual range standard)		○			
Wrapping Unit	Packs Per Minute	Up to 35ppm		○			
	Wrapping Capacity	0.02 - 6kg / 0.01 - 13lb (Up to 4.5kg / 9.9lb for a pre-wrapped tray)		○			
	Wrapping Size *2	Width: 95 - 380mm (3.7 - 14.9inch)			○		
		Depth: 80 - 260mm (3.1 - 10.2inch)			○		
		Height: 10 - 130mm (0.4 - 5.1inch)			○		
		Tray Height: 70mm max. (2.7inch)			○		
	Film Type	Polyolefin / PVC (type for machine use)		○			
	Film Size	250, 300, 350, 400, 450, 500, 533mm (21inch)		○			
Film Outside Diameter	φ200mm or less		○				
Number of film Roll	Automatic film selection available (two rolls only)		1	2	1	2	
Controller Unit	Display Console	Backlit 12.1-inch color LCD touch-panel (SVGA: 800×600dots)			○		
	Tactile Keys	19 Keys			○		
Printer Unit	Print Head	3inch direct thermal (960dots), 12dots/mm, 80mm wide head			○		
	Printing Speed	120mm/sec			○		
	Print Area	Width: Up to 76mm (3.0inch)			○		
		Height: <Printer #1: Left> 27 - 105mm (1.1 - 4.1inch)			○		
		<Printer #2: Right> 27 - 60mm (1.1 - 2.4inch)				○	
	Label Size	Width: 35 - 80mm (1.4 - 3.2inch)			○		
		Height: <Printer #1: Left> 27 - 105mm (1.1 - 4.1inch)			○		
		<Printer #2: Right> 27 - 60mm (1.1 - 2.4inch)				○	
	Number of Upper Printer		1	1	2	2	
	Label Roll Size -Inner Core Diameter	φ76mm (3.0inch)			○		
-Outer Core Diameter	φ230mm (9.0inch) or less			○			
Label Storage Capacity	6,000labels/roll (at 37mm (H) and 2.2mm gap)			○			
Interface	Ethernet	RJ45 x 1, 1000B-T			○		
	Wireless	802.11b/g *3			○		
	USB	x 4, USB 2.0			○		
	Scanner	via USB interface			○		
Others	Power Supply	Single phase, AC 200 - 240V (+5% / -10%), 50/60Hz, 10A			○		
	Power Consumption	Standby: 360W or less, Maximum: 1800W *4			○		
	Sleep Mode	90W or less			○		
	Memory Capacity	2GB			○		
	Dimensions	1215 × 1120 × 1635mm (Width × Depth × Height)			○		
	Foot Print	1000 × 1120mm (Width × Depth)			○		
	Occupied Space	-Width	1365mm with film cover opened			○	
		-Depth	1550mm with stock conveyer or film cover opened			○	
	Weight	Approx. 382kg			○		
	Noise Level	74.6dB or less			○		
	Operation Environment	Temperature: 5°C - 35°C, Humidity: 20% - 85% (No condensation)			○		
Standards	ETL, CE, EU type approval			○			

*1: Factory fitted option

*2: Maximum dimensions cannot be used in combination.

*3: Optional

*4: Power consumption varies dependent on site conditions and machine setup.

Specification subject to change without notice.



<WM-AI AS2 JR>

DIMENSIONS

(mm)

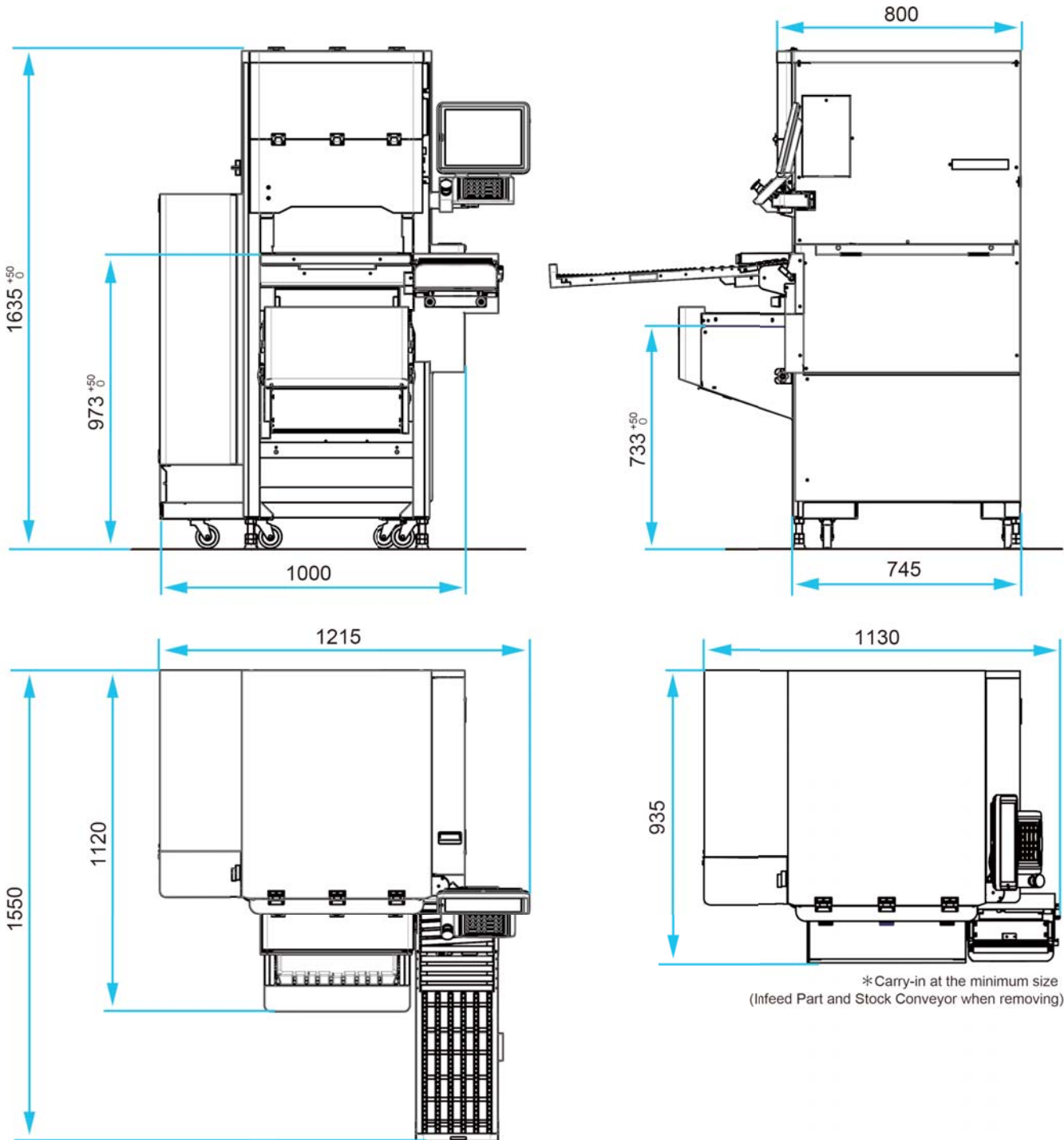

ISHIDA CO., LTD.

44,SANNO-CHO, SHOGOIN SAKYO-KU,
KYOTO 606-8392 JAPAN
Phone : 81-75-771-4141 Facsimile : 81-75-751-1634